

ELECTRIC

RANGE COOKERS

160 YEARS OF HOME COOKING

ELECTRIC RANGE COOKERS

Radiant heat with added cooking control

Our electric range cookers feature independently controlled temperature settings and ESSE's power share system optimises performance to ensure all the elements work together in harmony whether a single hotplate or the whole cooker is in use.

The slumber mode oven and hotplate temperature pre-sets maintain economical power usage, shortening heat-up times prior to cooking and our 1000 models include a programmable timer for the ultimate in efficiency and control.

The high thermal mass of ESSE electric ovens provides a stable temperature and the oven surfaces are heated by our unique patented surround element technology.

This means temperatures are consistent throughout the space, so there's no need to turn dishes during cooking and they can even be placed directly on the base of the oven to cook.

Use the cast iron hotplate for boiling and frying, lower the temperature for simmering and griddling direct on the hob and when you need hot water in a hurry, the induction zone brings a panful to the boil almost instantly.

With no flue required an ESSE electric range cooker can be positioned in a location of your choice with standard power sockets.

And while you're preparing a meal your ESSE is also ensuring the kitchen remains warm and welcoming at all times.

1000 T

Page 4



985mm

600 T

Page 5



595mm

1000 X

Page 6



985mm

600 X

Page 7



595mm

1000 T

ELECTRIC RANGE COOKER



ESSE's 1000 T range cooker is the traditional kitchen star – whatever the recipe and however many guests.

The 1000 T incorporates two independently controlled ovens, a full-width integrated grill in the top right oven, a temperature-set slow cooking oven and an induction hob alongside a cast iron hotplate and – with no flue required – this clever cooker will fit anywhere.

A programmable timer with countdown and temperature presets takes care of everything from the perfect soft-boiled egg for breakfast to cooking the Sunday roast.

The lower left oven is ideal for warming the plates for dinner or leaving a dish overnight for that delicious slow-cooked succulence.

Independent steam vents on top of the cooker allow humid ovens for baking and steaming and, when opened, allow that steam to escape for perfectly crisp roast potatoes.

- 1 Induction zone
- 2 Cast iron hob
- 3 Control panel
- 4 42ltr electric oven and full-width grill
- 5 Slow cook oven
- 6 30ltr electric oven
- 7 Runs on 2 x 15AMP sockets



Independent oven control

ESSE'S UNIQUE SURROUND HEAT CREATES

A MORE EVEN TEMPERATURE



PRODUCING
EVEN BETTER COOKING

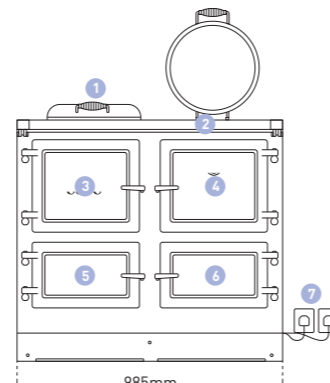

600 T

ELECTRIC RANGE COOKER



A compact electric range cooker that fits comfortably in any size kitchen.

Comprising separate top and bottom ovens, a full-width grill and a generous cast iron hotplate accommodating multiple pans, the 600 T delivers the plug in and cook flexibility of a modern cooker with all the style and elegance of an ESSE.

The 600 T slots easily into the space reserved for a standard cooker, providing the beauty of a cast iron stove with the amazing roasting and baking qualities of an ESSE range.



The dials for ovens, grill and hob are neatly housed in a stand alone external control panel which can be free standing or wall-mounted.

- 1 Control panel
- 2 Cast iron hotplate
- 3 42ltr electric oven and full-width grill
- 4 30ltr electric oven
- 5 Runs on 1 x 15AMP socket

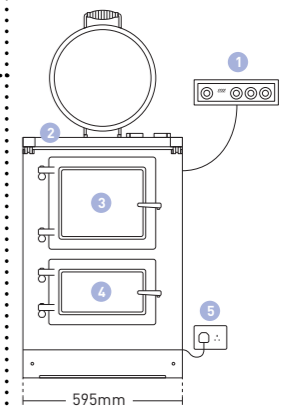

UNRIVALLED COOKING QUALITIES
IN A
COMPACT RANGE

INDEPENDENT, ADJUSTABLE
STEAM VENTS
FOR EACH OVEN

VOLUMINOUS OVENS
DESIGNED FOR DEPTH
RATHER THAN WIDTH
TO
RETAIN HEAT

1000 X

ELECTRIC RANGE COOKER



This electric range cooker features the same independent ovens and grill with concealed control panel as the popular 1000 T yet gives owners a little e'X'tra capacity for entertaining.

With double the hob space, the contemporary 1000 X provides additional room for creative cooking and simple three pot wonders.

The three induction zone with cast iron plate combination and striking large lids are designed with the committed cook in mind.

The heat-conserving rectangular lids are beautifully engineered for easy lifting and

feature an elegant recessed drop hinge a feature first used on ESSEs in the 1950s. When the cooker is in use the lids double up as a splashback.

From melt-in-the-mouth meringues and slow-cooked stews to deliciously crispy roast potatoes or a full English breakfast for 12, the 1000 X is a true all-rounder; a modern classic that's ready to plug in and go to work in any setting.

TAKES MINUTES

TO HEAT UP (NOT HOURS!)

ESSE'S ENERGY EFFICIENT

POWER SHARE ENGINEERING

GIVES YOU POWER WHERE YOU NEED IT MOST AT ANY ONE TIME

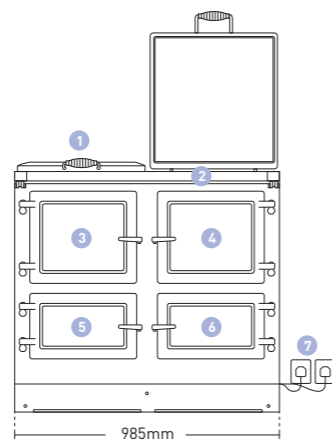

- 1 Three-zone induction hotplate
- 2 Large cooking plate with centre round cast iron plate
- 3 Control panel
- 4 42ltr electric oven and full-width grill
- 5 Slow cook oven
- 6 30ltr electric oven
- 7 Runs on 2 x 15AMP sockets

600 X

ELECTRIC RANGE COOKER



A compact electric range cooker that fits comfortably in any size kitchen.

Comprising separate top and bottom ovens, a full-width grill and a generous cast iron hotplate accommodating multiple pans, the 600 X delivers the plug in and go flexibility of a modern cooker with all the style and background heat of an ESSE.

The 600 X slots easily into the space reserved for a standard cooker, providing the beauty of a cast iron stove with the amazing roasting and baking qualities of an ESSE range.



Powerful, full width grill



The dials for ovens, grill and hob are neatly housed in a stand alone external control panel which can be free standing or wall-mounted.

- 1 Control panel
- 2 Cast iron hotplate
- 3 42ltr electric oven and full-width grill
- 4 30ltr electric oven
- 5 Runs on 1 x 15AMP socket

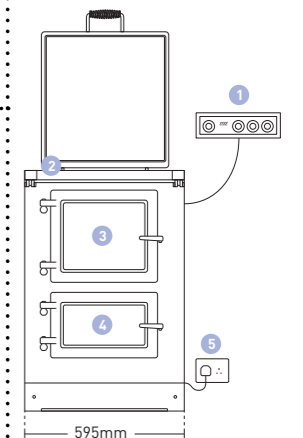

UNRIVALLED COOKING QUALITIES
IN A
COMPACT RANGE

NEW CENTRE
HOT(TER)PLATE
DESIGN

VOLUMINOUS OVENS
DESIGNED FOR DEPTH
RATHER THAN WIDTH
TO
RETAIN HEAT



Black
(nearest RAL colour: 9005)



Cream
(nearest RAL colour: 1015)



Pepper
(nearest RAL colour: 2002)



Sage
(nearest RAL colour: 140 60 10)



Shadow
(nearest RAL colour: 5008)



White
(nearest RAL colour: 9003)

6

COLOURS AVAILABLE

Indulge your inner interior designer

When you place an ESSE at the heart of your kitchen, choosing the ideal colour is key.

Strike the perfect tone from our choice of six of the best range cooker colours – ranging from the timeless Black and Cream to Sage and dramatic Pepper.

Since the early 1900s ESSE cookers have been available in hard wearing colour finishes skilfully applied by hand in our factory.

INCREASE CAPACITY

Match up a 600 with a 1000 to give more capacity.



600 T & 1000 T

Colour: Pepper

EXTRACTION HOODS

Compatible with flueless electric cookers, our hoods 'draw' the air through their easy-clean filters, neutralising unwanted odours and vapours.

With a choice of four settings, our hoods deliver a maximum extraction rate of 1000m³/hr. For maximum convenience, they can be operated manually or by using a 10 minute auto-programme.



NB: We are constantly developing and improving our products and we reserve the right to alter specifications without prior notice. Due to the limitations of the printing process, it is not possible to replicate cooker colours exactly as shown in our printed material. But trust us, they're better in person.

TECHNICAL SPECIFICATIONS

ELECTRIC MODEL TEST METHOD

In a controlled factory environment maintaining an average room temperature of 15°C the cooker is run at slumber for 1hr. All controls are turned up to full and within 1hr, full temperature on all cooking zones are reached. It is then run for a further 1hr, to simulate cooking.

The cooker is then returned to slumber for a remainder of 24hrs. Temperature measurements are taken every second and power readings taken at key points. Heat up to max + 1hr cooking = 5kW in 2hrs. The cooker runs at less than 2kW/hr once at max temp.

600 T

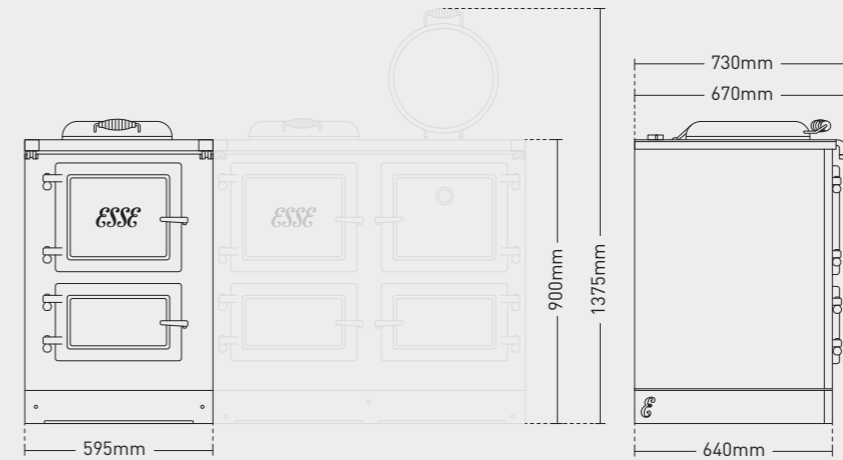

Electricity supply	1 x 15AMP 220 - 240V
Weight	200kg
TOP OVEN CAPACITY	42 litres
W: 360mm H: 305mm D:460mm	
BOTTOM OVEN CAPACITY	30 litres
W: 360mm H: 205mm D:460mm	
Power consumption in slumber	0.32kW/hr
HEAT UP TIMES (from slumber)	
Top oven from 155°C to 240°C	20 mins
Bottom oven from 70°C to 175°C	15 mins
Cast iron hotplate from 150°C to 350°C	30 mins
Cast Iron hotplate from 150°C to 200°C	7 mins

1000 T

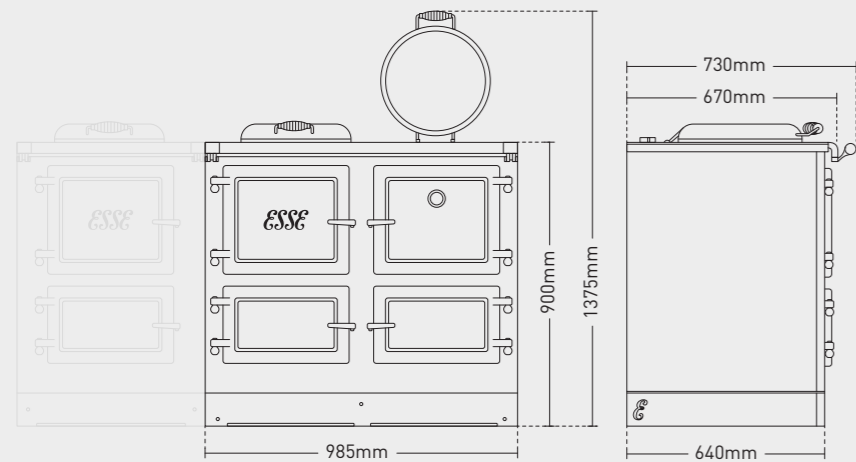

Electricity supply	2 x 15AMP 220 - 240V
Weight	327kg
TOP OVEN CAPACITY	42 litres
W: 360mm H: 305mm D:460mm	
BOTTOM OVEN CAPACITY	30 litres
W: 360mm H: 205mm D:460mm	
Power consumption in slumber	0.4kW/hr
HEAT UP TIMES (from slumber)	
Top oven from 155°C to 240°C	15 mins
Bottom right oven from 70°C to 175°C	15 mins
Cast iron hotplate from 150°C to 350°C	30 mins
Cast iron hotplate from 150°C to 200°C	7 mins
Induction	Instant
Compatible with extraction hood	

600 X

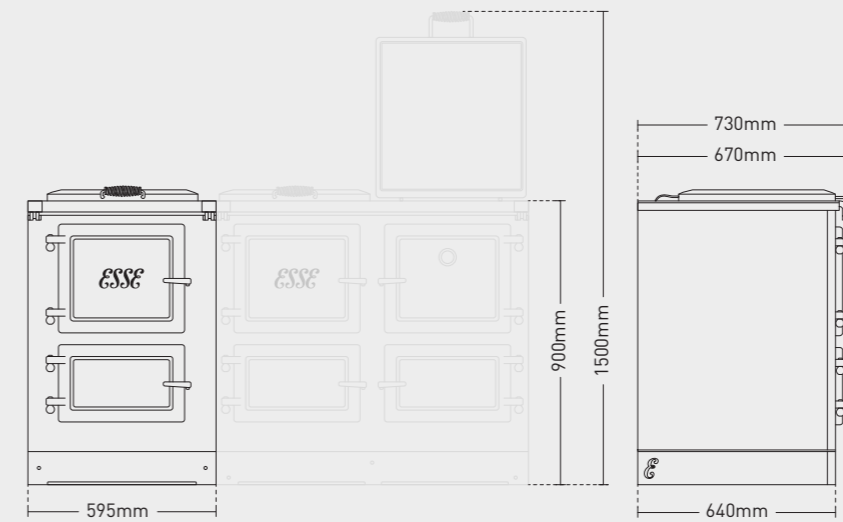

Electricity supply	1 x 15AMP 220 - 240V
Weight	200kg
TOP OVEN CAPACITY	42 litres
W: 360mm H: 305mm D:460mm	
BOTTOM OVEN CAPACITY	30 litres
W: 360mm H: 205mm D:460mm	
Power consumption in slumber	0.32kW/hr
HEAT UP TIMES (from slumber)	
Top oven from 155°C to 240°C	20 mins
Bottom oven from 70°C to 175°C	15 mins
Cast iron hotplate from 150°C to 350°C	30 mins
Cast Iron hotplate from 150°C to 200°C	7 mins

1000 X

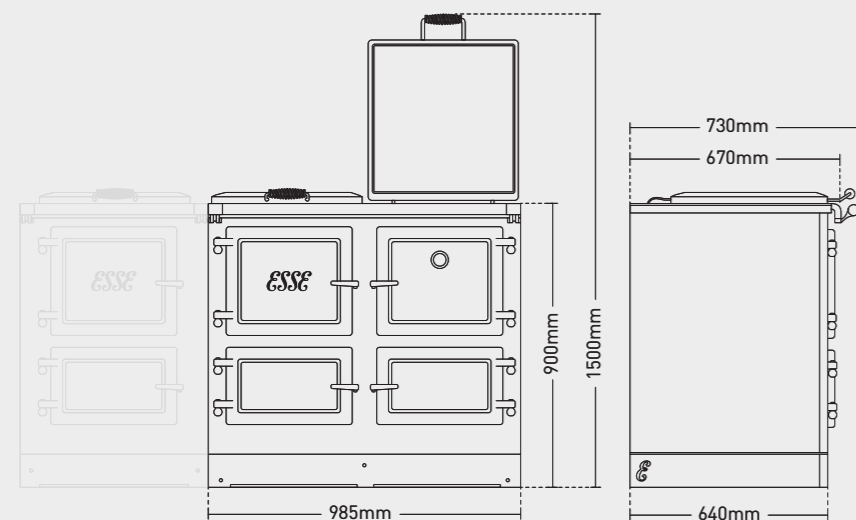

Electricity supply	2 x 15AMP 220 - 240V
Weight	327kg
TOP OVEN CAPACITY	42 litres
W: 360mm H: 305mm D:460mm	
BOTTOM OVEN CAPACITY	30 litres
W: 360mm H: 205mm D:460mm	
Power consumption in slumber	0.5kW/hr
HEAT UP TIMES (from slumber)	
Top oven from 155°C to 240°C	15 mins
Bottom right oven from 70°C to 175°C	15 mins
Cast iron hotplate from 150°C to 350°C	30 mins
Cast iron hotplate from 150°C to 200°C	7 mins
Three-zone Induction	Instant
Compatible with extraction hood	

1600 T

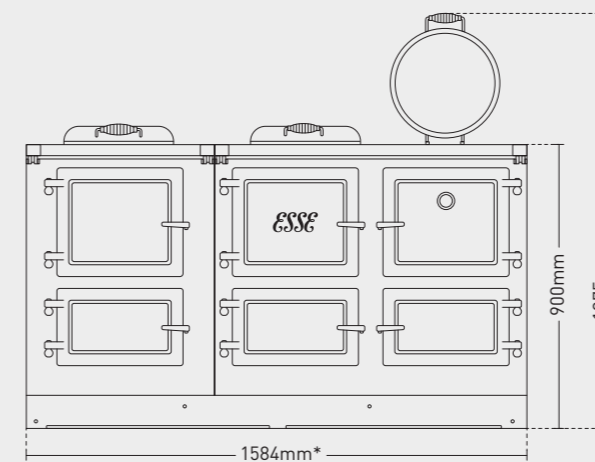

1600 X

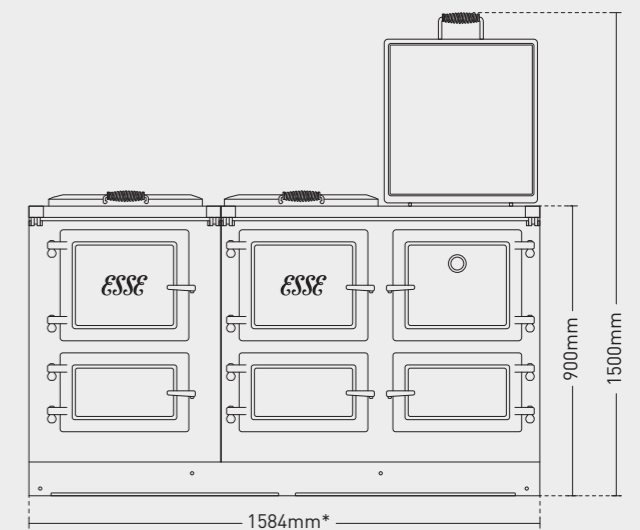

* Width includes a fitting tolerance. For more information visit pivotstove.co.nz

A CHOICE OF

LOOK

WHICH WILL YOU CHOOSE?



COOKING WITH

HEART & SOUL

GOES ELECTRIC

40% LARGER HOTPLATE



When compared to 500 / 990 EL

PATENTED SURROUND HEAT



ON ALL MODELS



NEW CENTRE DESIGN

HOT(TER)PLATE



When compared to 990 EL

INDEPENDENT, ADJUSTABLE STEAM VENTS FOR EACH OVEN



All Models

SMILE! IT'S 15 AMP





Available in

6

Colours



POWERFUL, FULL WIDTH

All Models

TWO WIDTHS



1000MM AND 600MM





TRIED AND TESTED

-
- 1854** National hero and pioneer of modern nursing, FLORENCE NIGHTINGALE, was passionate about ESSE cookers and would use no other brand at her field hospital. in Balaclava 🏠 during the CRIMEAN WAR.
- 1909** Explorer SIR ERNEST SHACKLETON relied upon an ESSE cooker to provide hot food and warmth to his shore party 🚢 during his British ANTARCTIC EXPEDITION. The ESSE 'Mrs Sam' stove still stands in Shackleton's base hut at Cape Royds.
- 1985** ESSE makes its big screen debut appearing alongside SIR ROGER MOORE as JAMES BOND in 🎬 'A View To Kill'.
- 2019** And today, ESSE stoves provide heat on HRH KING CHARLES'S estate at Dumfries House in Ayrshire 🌳 and they are counted on to provide delicious food in Hugh Fearnley-Whittingstall's RIVER COTTAGE kitchens.
-



When Sir Ernest Shackleton set out to conquer the Antarctic, he needed a stove that would perform in the most hostile of conditions. He chose an ESSE. Just one story from ESSE's rich heritage.

SIR ERNEST SHACKLETON & HIS CREW

RANGE
COOKERS

Beautifully

**HAND-CRAFTED
IN  BRITAIN**



Contact your local Kouzina store

sales@kouzina.co.nz - 0800 388 383

AUCKLAND

155 The Strand, Parnell
09 377 7822

QUEENSTOWN

313 Hawthorne Drive, Frankton
03 428 2731

CHRISTCHURCH

148 Victoria Street,
Christchurch Central
03 365 8338

ESSE

"ESSE" is a trade mark of ESSE Engineering Limited © 2023. All rights reserved.
Please don't reproduce any part of this publication without permission from ESSE Engineering Limited. Thank you.

Visit pivotstove.co.nz for more information