

INFORMATION FOR USE WHEN ORDERING SPARES:

08/11 (PP)
INSTR.CK-EC4i/u

Model: _____
Serial Number: _____
Colour: _____

GUARANTEE

Conditions of Guarantee

Your ESSE cooker is guaranteed against defects arising from faulty manufacture for two years, subject to the following express conditions:

- A suitably qualified person must install the cooker, and upon installation the details must be recorded on the warranty card and registered with ESSE by returning the correctly completed card. The guarantee period commences upon delivery of the cooker.
- The cooker has been used for normal domestic purposes only, and in accordance with the manufacturer's instructions.
- The cooker has not been serviced, maintained, repaired, taken apart, or tampered with by any person not authorised by us.
- An approved dealer or representative must undertake all service work under this guarantee.
- Any cooker or defective part replaced shall become the Company's property.

Exclusions

This guarantee does not cover:

- Damage or calls resulting from transportation, improper use or neglect.
- Parts deemed to be replaceable in the normal usage of the cooker; e.g. thermostats, elements, induction hob elements, fans, energy regulators, switches etc.
- Control Panel Markings; these can become damaged if a hard abrasive is used.
- Ceramic Glass Hob; any inherent flaw or defect in the ceramic glass will be immediately evident.
- Enamel damage; the vitreous coating on your cooker is in effect an extremely thin layer of glass and as such displays all the characteristics of glass. It can easily be damaged by impact, or by spillage of cold liquids onto a hot surface. Such damage cannot be covered under this guarantee. (See also intermittent use of your cooker, below).

This guarantee is personal to the original purchaser and is non-transferable.

Intermittent Use of Your Cooker

In the event of intermittent use and prolonged shutdown, it should be noted that in some circumstances enamel may be displaced due to ingress of damp. Whilst this is rare, it is most likely to occur in situations where the unused cooker remains in an unheated property. There is a layer (known as the groundcoat) between the vitreous enamel surface and the cast iron. Groundcoat is porous and if exposed (e.g. after a chip in the vitreous enamel coat), may allow damp to penetrate behind the vitreous enamel and spread through the groundcoat. Surface oxidation of the cast iron may thereafter occur, causing the vitreous enamel to fall off. Such damage will not be covered by your warranty. We recommend that a light coating of petroleum jelly be applied to any damaged areas when the cooker is not in use to help keep out the damp.

Customer Care

In the event you should require spare parts, please order through your ESSE dealer. Alternatively from our online spares store.

Should you have cause for dissatisfaction with your cooker, you should contact your ESSE dealer, who will, in most instances, be able to offer you immediate assistance. You will be required to give the following details:

- Your name, address and postcode.
- Your telephone/contact details.
- Clear and concise details of the fault.
- Model and serial number of the cooker (found on the data plate inside the warming cupboard on the back face).
- Purchase date (please note that a valid purchase receipt or guarantee documentation is required for in-guarantee service calls).

We will then check that we have an accurately completed warranty card, if not then any work carried out may be charged.



Esse Engineering Limited, Long Ing, Barnoldswick, Lancashire BB18 6BN

Tel: 01282 813235 Fax: 01282 816876 e-mail: enquiries@esse.com

Website: <http://www.esse.com> On-line Store: <http://www.esseparts.com>

ESSE Electric Cooker

OPERATING & INSTALLATION INSTRUCTIONS

MODEL: INDUCTION EC4i



CONTENTS

Technical Data	Page 3	Hob Touch Controls	Page 9
Unpacking	Page 3	Operating Instructions	Page 11
Your Cooker	Page 4	Before Cooking	Page 15
Spacing & Dimensions/Extraction	Page 5	Cleaning	Page 15
Connecting the Cooker	Page 6	Servicing Instructions	Page 16
Ovens & Grill	Page 6	Wiring Diagram	Page 17
Induction Hob	Page 9		

TECHNICAL DATA

ESSE, ENGLAND	MODEL	ESSE, ELECTRIC	VOLTAGE	- 250V
INPUT	45A	SERIAL No.	SUPPLY	50 Hz a.c.

The cooker Data Plate is located inside the right hand side lower oven door.

UNPACKING

After unpacking the cooker, remove all the packing from the top and bottom ovens including protective film on door liners. Examine the cooker for any damage, particularly to the hob glass.

If there is any damage to the cooker or anything is missing, please contact your supplier for advice.



If the hob is cracked the cooker must not be connected, and no part of it may be used.

NOTE

YOUR COOKER

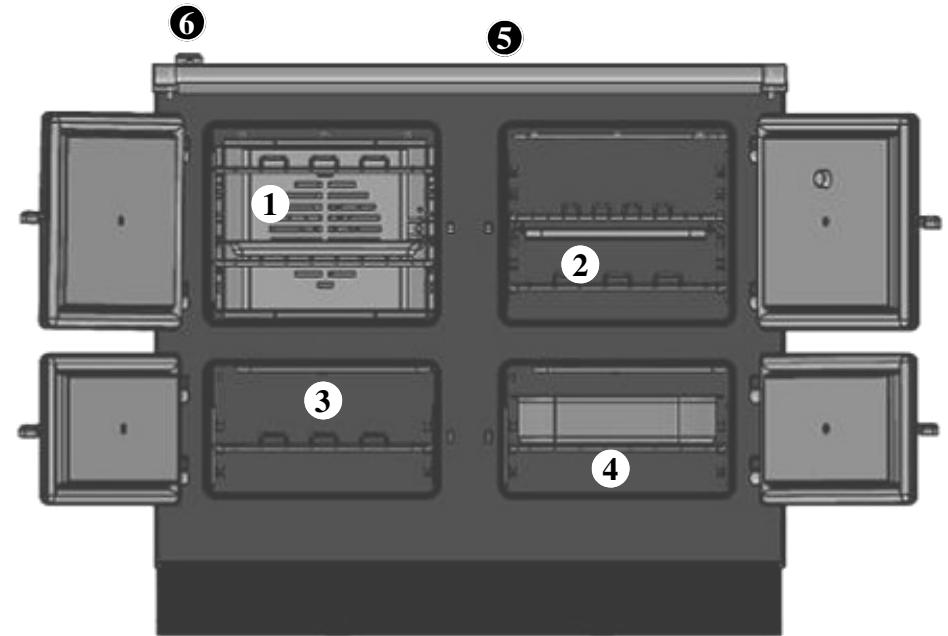

Fig. 1

1. Main Fan Oven
2. Main Conventional Oven & Grill
3. Slow Oven
4. Lower Conventional Oven
5. 5 Zone Induction Hob
6. Oven Control Panel

SPACING & DIMENSIONS

All dimensions are shown in mm.

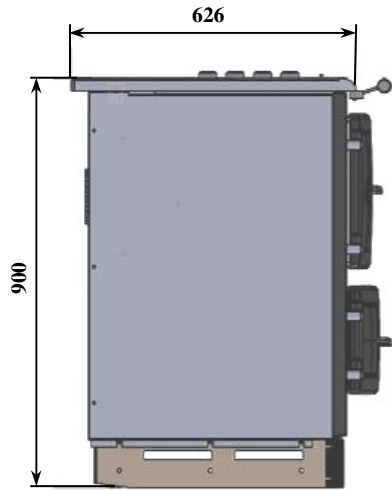

Fig. 2

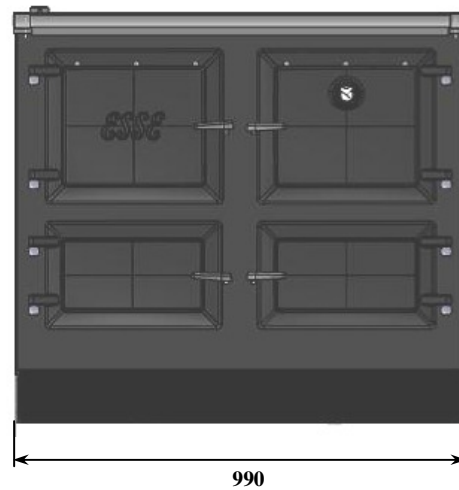

Fig. 3

The cooker weighs 200kg and so the floor must be capable of withstanding the load.

If the floor is not level the cooker should be made level with the use of packing pieces. The cooker does not require access via the side panels once it is installed and so kitchen units can be butted up to the sides of the cooker.

It is not recommended that the cooker be positioned below wall cupboards, as heat and steam from the cooker may cause damage to the cupboard and its contents.

EXTRACTION

An extractor may be used with this appliance.

CONNECTING THE COOKER

For your own safety, we recommend that a competent person, such as a qualified electrician, install your cooker. The cooker should be installed in accordance with the latest Edition of the IEE Regulations.



This cooker must be earthed.

WARNING

The cooker must be connected to the correct electrical supply (as stated on the rating plate, see page 3) through a suitable cooker control unit incorporating a double pole switch having a contact separation of at least 3mm in all poles, adjacent to (but not above) the cooker. We recommend that the cooker circuit be rated to 45amps. We recommend that 6mm P.V.C. insulated twin and earth cable is used to connect the cooker to the cooker control unit.

The cable must be BASEC or HAR approved. Preferably allow sufficient cable length for the cooker to be pulled out if need be, but do not let it hang closer than 50mm (2") to the floor. The cable can be looped if necessary, but make sure that it is not kinked or trapped when the cooker is in position.

We supply a length of cable ready to connect to the 45 amp switch

Access to the cooker terminal block is by removing the rear access panel.



The mains supply cable must be securely clamped by the cable clamp so that any tension applied to the supply cable must not be transmitted through to the terminal block.

NOTE

OVENS & GRILL

Controlled by the 5 knobs positioned on the left of the hob. Temperature markings are in degrees Celcius. To switch one of the ovens on, turn the corresponding knob clockwise to the chosen temperature. The indicator light will illuminate to show that the oven is heating and will go off when the oven has reached selected temperature.

Main Fan Oven

High efficiency fan assisted 2kW, 37 litre oven. Heats up quickly from cold and offers even cooking temperatures throughout the space; great for batch cooking as the same results will be achieved on each shelf. Recommended cooking times can be reduced for this oven, saving even more energy. (See Figs. 1 & 4)



NOTE

It may be necessary to adjust either cooking times or temperatures if transferring recipes from conventional ovens. For example, if a recipe states 180C, it may require a fanned oven temperature of 160C. Ensure there is sufficient space around the food to allow air circulation.

Main Conventional Oven

1.9kW 37 litre conventional oven with 2kW grill. This capacious oven is ideal for roasting and baking; particularly perfect for pies, pastries and breads. At lower temperatures, it can also be used as a slow cooker - ideal for tender Christmas turkey! Unlike many traditional range cookers, the EC4i includes a full-width grill so you don't have to compromise the way you cook. The grill can also make this main oven a browning oven. (See Figs. 1 & 4)

Fig. 4



Main Fan Oven Control

Main Conventional Oven Control

Grill Control

Lower Conventional Oven Control

Slow Oven Control

Slow Oven

900W, 25 litre Slow oven (120°C). The slow oven has been designed for cooking melt-in-the-mouth stews and casseroles. It's also well-suited to speciality recipes such as meringues and can be used for warming pre-cooked dishes without drying them out. (See Figs 1 & 4)

Lower Conventional Oven

900W 25 litre, conventional oven. A useful secondary oven, perfect for Yorkshire puddings and all the trimmings that complement a roast dinner. Thanks to each oven's independent operation, you could even bake dessert in here while your meal cooks. (See Figs 1 & 4)

All four ovens are easy-clean and have handy 'slam-shut' doors

Oven Safety Points

- When using the oven shelves ensure they are correctly placed between the shelf runners.
- Always use oven gloves when removing food from either the ovens or grill.



Only use grill with door open

IMPORTANT



The front, top and doors of the cooker may become hot after long periods of use. Keep children and animals away.

WARNING

Heating

With either of the lower ovens turned on the cooker will become warm to the touch and will radiate heat into the kitchen. At a setting of 80°C the cooker will consume approximately 1/3 kW of electricity per hour.

Condensation

Condensation will be produced when cooking food with a high water content, especially if the body of the cooker is cold. Before cooking, pre-heat the oven until the cast iron door becomes warm, this will reduce the amount of condensation when the food is introduced.

Oven Cleaning

Ovens are coated in vitreous enamel and can be cleaned with normal oven cleaning products. Shelf supports are removable for easier cleaning. The areas under the tops of the ovens are self cleaning and cleaning should not be attempted here.

INDUCTION HOB

Hob Safety Points

- The cooking surface may get hot even in the case of inductive heating, as a hot pan will transfer some heat back to the glass surface.
- It is inadvisable at any time to leave a heating element switched on without a pan in position as this wastes energy, and could make marks more difficult to remove.
- Never cook directly on the hob surface without a cooking pan as this will result in damage to the surface of the hob.
- Never use the hob as a work surface as damage may occur to the smooth surface of the hob.
- Never drag or slide pans on the hob surface, as this will cause scratches in the surface of the hob.
- Never leave any utensils, food or combustible items on the hob when it is not in use.
- Never place plastic foil or plastic containers on the hob as damage will occur.
- Always ensure the base of the utensil is dry before placing it on the hob.
- Never use utensils with rough bases.
- It is important that any spillage is dealt with before the hob is used again, otherwise it may become baked on.
- Remove any spillage of high sugar content, such as jam, immediately. Use a pan, which is large enough to prevent boil over or spillage.
- Before using the hob for the first time we recommend you clean the glass surface with ceramic hob cleaner and conditioner, such as Hob-brite. This applies a thin protective film to the hob, making it easier to clean and prolonging its life.

Pans



IMPORTANT

It is essential to use pans suitable for induction cooking. These have to have a ferrous content, so cast iron and magnetic stainless steel are ideal but copper, aluminium and ceramic pans will not normally work.

Fig. 5 - Hob Touch Controls

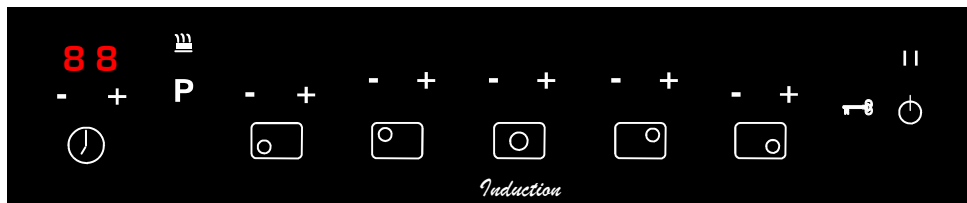

	Front Left Hob		Front Right Hob		Pause/Resume Icon (4)
	Back Left Hob		Power Icon - On/Off (1)		Lock Icon (7)
	Centre Hob		Boost Icon (2)		Timer Icon (5)
	Back Right Hob		Simmer Icon (3)		Timer LED Display (6)

Fig. 6 - Glass Hob



OPERATING INSTRUCTIONS (See Page 9 - Fig. 5 for details of icons and symbols)

Make sure that there are no objects over the sensors or on the hob. Metallic objects such as knives, forks, spoons and lids should not be placed on the hob surface since they can get hot.

Switch on the hob at the mains supply. When the hob is switched on at the mains, basic calibration is carried out automatically - this will take about 5 - 10 seconds.

(Sometimes an illuminated 'H' will appear in the space next to the controls for certain elements when the hob is first connected to the mains. This is a consequence of the factory testing procedure, and the 'H's will disappear during the first hour of connection to the mains.)

The hob is now in the 'OFF' mode.

OFF mode

The hob is switched on at the mains supply. All heating elements are switched off, and displays are not illuminated. Touch the main 'ON/OFF' sensor (1) to bring the hob to the 'WAIT' mode. Note: a buzzer will sound to confirm that the touch control system has recognised the touch.

WAIT mode

When the hob goes to 'WAIT' mode, '0' appears in each heating element display for 10 seconds. If no sensor is touched within 10 seconds the hob returns to 'OFF'. If a heating element sensor is touched while the hob is in 'WAIT' mode, the hob will go into 'ACTIVE' mode.

ACTIVE mode

When at least one heater is on (setting 1-9), the hob is in the 'ACTIVE' mode. If no heating elements are pressed on, and no sensor is activated within 10 seconds, the hob returns to 'OFF'.

Pan Detector

Each cooking zone has a pan detector, and will not work unless a pan is in place. If a pan is removed from the cooking zone during cooking, the zone will switch off, and the display will alternate between the chosen power setting and the \cup symbol (no pan). The pan detector will only recognise pans made of a suitable material, i.e. ferrous metal, and may not recognise a pan that is too small. We do not recommend the use of pans smaller than the marked ring.

To switch on a heating element



Touch the main 'ON/OFF' sensor to bring the hob into 'WAIT' mode. All heating element indicators will come onto '0', and remain on for 10 seconds. While '0' is showing on the display, any heating element can be switched on. To switch on an element, ensure that a suitable pan is in place, then touch either the '+' or '-' sensor relating to that element. When you touch the '+' sensor to switch on any heating element the display will show a medium heat setting (4). When you touch the '-' sensor to switch on any heating element the display will show high heat setting (9). Use the '+' and '-' sensors to select the required heat setting.

To switch off

To switch off an individual heating element, touch the '-' sensor for that heater until the number in the display reaches '0', or touch both '+' and '-' sensors simultaneously.

To switch off all the heating elements, touch the 'ON/OFF' sensor (1).

After a heater has been switched off, the display will show 'H' (hot) until the glass has cooled.

We recommend that you switch off the hob at the mains when it is not in use, to avoid accidental activation of the sensors.



IMPORTANT

Please note that when the hob is switched off at the mains, the 'H' will disappear, and it is recommended that you leave the hob switched on until the cooling fans stop operating.

Automatic heat-up function

The automatic heat-up function provides full output power during the initial heating stage, and then reverts to a pre-selected power level, perhaps for simmering.

To activate the automatic heat-up function, switch on the required cooking zone using the '-' sensor. '9' will be shown on the display. Now touch the '+' sensor, the display will change to 'A'. Next, use the '-' sensor to cycle through to the required lower power setting. The display will show 'A' and your chosen setting alternating during the heat-up period, and then just your chosen setting when the output power drops to your setting. As an example, setting the automatic heat-up function with a chosen lower setting of '3' results in the cooking zone working at full power for two minutes, and then reverting to setting 3.

Boost function

Each cooking zone can be boosted to a higher power level for faster cooking. In some cases this is achieved by limiting power to an adjacent cooking zone.

To set the boost function, ensure that the cooking zone is 'active' i.e. '0' to '9' are shown on the display. Touch the 'P' (Power) sensor (2), An LED next to the 'P' sensor will flash. Then touch either the '+' or '-' sensor of the cooking zone to be boosted. The symbol 'P' will appear in the display of any zone in boost mode.

To turn off the boost function touch '-' and '+' sensors of the appropriate zone simultaneously. Note, touch the '-' sensor and the zone will revert to setting '9', after which the zone can be controlled in the normal way using the '-' and '+' sensors.



WARNING

Because of the rapid heating action of the boost function, your hob should never be left unsupervised while it is in use; not even for a short while.

For safety reasons, the boost function is automatically terminated after 10 minutes.

Keep warm function

Each cooking zone can be used as a keep warm zone.

To set the keep warm function, ensure that the cooking zone is 'active', i.e. '0' to '9' are shown in the display. Touch the (keep warm) sensor (3). An LED next to the 'keep warm' sensor will flash. then touch either the '+' or '-' sensor of the cooking zone to be used as the keep warm zone. The symbol 'U' will appear in the display.

To prevent food from drying out always put a lid on the pan. Remember, the keep warm function can only work using suitable pans, you cannot, for example, use the system to keep a plated meal warm. The keep warm function is automatically terminated after two hours.

To switch off the keep warm function touch the '-' sensor of the appropriate zone and the display will show '0'. Note, touch the '+' sensor and the zone will cycle first to '1' through to '9' depending upon how long the sensor is touched.



WARNING

When using this function, food should only be kept warm for a very short time. The longer food is kept warm after cooking, the greater the loss of nutrients and risk of bacterial contamination.

Pause function

The pause function allows cooking to be suspended, then re-started at the original settings. With at least one cooking zone in operation the pause function is activated as follows: touch the '||' (pause) sensor (4) for one second. An LED will illuminate next to the pause button, and '||' will appear in each of the cooking zone power displays. To re-start cooking, touch the pause sensor again for one second. The LED next to the pause button will flash for ten seconds. During this period, touch the power sensor (1) and cooking will re-start at the original settings. If the power sensor is not touched within ten seconds, the hob will be switched off.

Residual heat indication

The cooking surface of the hob can become hot in use through contact with the pan. After a heating zone has been switched off, the power level display (1) will show 'H' until the area is safe to touch.

List of display symbols

1 - 9	Power level
U	Food warming (65°)
P	Booster
A	Auto heat-up
<u>U</u>	Pan is absent or not suitable
H	Residual heat
E	External error
F	Fault
	Pause

Timer

A simple 'egg timer' (ranging up to 99 minutes) function is provided, and in addition each heating zone can be operated independently on its own timer. The two seven segment LED displays (6) display the remaining time in minutes until the timer alarm is activated or the selected heating zone is switched off.

The timer can also be set to switch off any cooking zone after a timed period.

The timer can be set to operate any cooking zone currently in use. Selecting which timer to set is done by simultaneously touching the timer '-' and '+' sensors (located above the  symbol). LEDs positioned around the timer display indicate which zone timer is selected. With each simultaneous touch of the '-' and '+' sensors the selection of the timer cycles in the following sequence: *front left - rear left - centre - rear right - front right*, ignoring those zones that are not in use. Having selected the zone to be timed, use the '+' and '-' sensors to select the timed period in minutes. The LED appropriate to the selected zone will flash. At the end of the timed period the zone will switch off and an alarm will sound and the display will flash. To switch off the alarm touch either the timer '+' or '-' sensor.

To operate just the 'egg timer', first switch on to 'WAIT' mode, where all the heating zone displays show '0'. Switch on the timer by touching the timer '-' and '+' sensors simultaneously. Now use the '+' and '-' sensors to select the timed period in minutes. The LED below the time display will flash. At the end of the timed period an alarm will sound and the display will flash. To switch off the alarm touch either the timer '+' or '-' sensor.

Lock function

The 'LOCK' function can be used to prevent the hob from being switched on unintentionally, or to prevent the settings being changed. This is intended to prevent children and those unfamiliar with the product from operating the hob.

To operate the lock function in order to prevent the cooking zones being switched on, switch on the hob so that all the displays show '0'. Now touch the 'LOCK' sensor (7) for approximately 2 seconds. An LED next to the sensor will come on, and a tone will sound. The hob will switch off after ten seconds. Now, when the power button is touched, all the displays will show '0' and the LED next to the lock sensor will be illuminated. None of the other sensors will work at this stage, so it is not possible to operate any of the cooking zones. To switch off the lock function, ensure that displays are on, (touch the power button to switch on the hob if the LEDs are not illuminated). Now touch the lock sensor for two seconds. The LED next to the lock sensor will go out and the hob can be operated normally.

The 'LOCK' function can also be used to lock the heating elements onto the selected power setting. After selecting the desired heating element setting, touch the 'LOCK' sensor for two seconds until the alarm sounds and the 'LOCK' LED illuminates. The lock function is switched off as described above.



If the appliance is disconnected from the mains supply, the lock function will be deactivated.

NOTE

Noises

Various noises may be heard when using an induction cooking pan, depending on how the pan is constructed. Noises may include a buzzing sound, particularly at higher power settings, clicking/cracking or whistling. The noise will get louder if the pan base is wet. It is recommended to use a dry pan base.

In addition, the appliance has a cooling fan that will come on during normal use, and will continue to run even after the cooking zones have been turned off.

Operation limits

The hob will only operate at a set power level for a limited period of time before it switches off automatically. This is to prevent overheating and to protect the electrical components.

Power setting	Approximate operation limit
U	2 hours
1	8 hours 40 minutes
2	6 hours 22 minutes
3	5 hours 18 minutes
4	4 hours 20 minutes
5	3 hours 33 minutes
6	2 hours 50 minutes
7	2 hours 19 minutes
8	1 hour 53 minutes
9	1 hour 30 minutes
P	10 minutes (plus a further 80 minutes at level 9)

BEFORE COOKING

Remove plastic protective covers from inner door linings.

Before you cook for the first time, it is recommended that all ovens be switched on at full power for about an hour in order to burn off any initial odours. The grill should also be turned on, with the top oven door open, for approximately 15 minutes before it is used for the first time.

CLEANING



WARNING

For your own safety, always switch off your cooker at the mains supply and allow cooling before cleaning.



NOTE

Never use excessive amounts of water to clean your cooker and always clean up any spillage immediately.

Hob Cleaning

It is recommended that the hob be cleaned daily with Hob Brite cleaner. Normally cleaning should be carried out when the hob is cooled, but, if jam, fruit or anything with a high sugar content is spilled on the hob, or plastic or aluminium is melted onto the hob, clean it off immediately, as damage to the hob can result. Switch off the hob and use a metal spatula, palette knife or scraper to remove the spillage. TAKE CARE, as the spillage and the hob may be very hot.

Do not use scouring powders or paste, wire wool scouring pads or oven cleaners on the hob as these may cause damage to the hob surface.

Oven Cleaning

Ovens are coated in vitreous enamel and can be cleaned with normal oven cleaning products. Shelf supports are removable for easier cleaning. The areas in the tops of the ovens are self cleaning and cleaning should not be attempted here.

General Cleaning

Enamel is simply a coloured glass coating added to the metal to give a durable and hygienic finish. It can be damaged by scratching or by a sudden application of cold liquids onto its surface when hot. Clean with a cloth and soapy water, preferably while the cooker is still warm. Proprietary non-scratch liquid cleaners for enamelled surfaces may be used. Spilled liquids should be removed as soon as possible. Fruit juices and other acidic products can remove the gloss surface from the enamel if left for any length of time. The door handles and the control knobs can be cleaned using metal polish. Do not use scouring powders or pastes, scouring pads or oven cleaners on the control panel fascia plate as this may damage the markings.

SERVICING INSTRUCTIONS



WARNING

Isolate the electrical supply before any repair work.

The cooker does not require regular servicing, but has been designed so that internal components are easy to replace in the event that they become faulty.

It is preferable that access to internal parts is made by lifting off the hob.

All the oven and grill elements can be removed and replaced from the front of the cooker through the oven openings.

To Remove the Base Element from the Bottom Oven

1. Remove the shelves and shelf supports from the oven.
2. Remove the two screws holding down the oven base at each side. Remove the base.
3. Undo the screw fastening the element to the side of the oven. The element can then be pulled out of the base of the oven. The electrical wire connections should stay attached to the element as it is pulled from the oven. The element wire terminals can then be swapped from the faulty element to the new element. Take care not to let the element wire connections fall back inside the cooker before they are reconnected to the new element.

To Remove the Upper Elements/Grill Element from the Top or Bottom Oven

1. Undo the single screw fastening the element to the side of the oven.
2. Loosen the screws on the element support brackets. The support brackets can then be rotated clear of the elements allowing the elements to fall.
3. The electrical wire connections should stay attached to the element as it is lowered. The element wire terminals can then be swapped from the faulty element to the new one. Take care not to let the element wire connections fall back inside the cooker before they are reconnected to the new element.

To Remove the Fan Unit from the Main Oven

Unscrew the six screws around the unit, pull the unit out with the wires attached, being careful not to allow them to fall back into the oven. Remove the fan guard by unscrewing the fixing screws on the top and two on the bottom of the unit.

To Remove the Induction Elements

Lift off the top.

Unbolt the 6 bolts holding the Induction support panel carefully. Each Induction coil will lift out.

To Replace the Element

Undo the 3 screws holding it, insert new element and replace wires.

To Replace the Motor

Unscrew the fan blade nut, unbolt the 3 fixing bolts, replace motor ensuring the spacing nuts and wires are correct!