



3 Garden Street, Morwell Vic 3840  
ABN: 46 610 154 768

**PREPARED FOR**

# **PIVOT STOVES & HEATING**



## **THERMAL TESTING OF THE PIVOT STOVES & HEATING ROOM SEAL FLUE KIT TO APPENDIX F OF AS/NZS2918:2018**

Report Number: ASFT20050-PRELIMINARY REPORT  
Issue date: 27 May 2020

By:  
Steve Marland

## Report Distribution

### Pivot Stoves & Heating

120 Victoria Street  
Nth Geelong VIC

Mr Greg Parker-Hill

ASFT Report Archive

## Revision Details

Revision	Date	Comments
0	27/05/2020	Preliminary report – awaiting payment and engineering drawings of Flue Kit

### Disclaimer

This Report is intended only for the use of the individual or entity named above (Intended Recipient). ASFT is not liable to the Intended Recipient in respect of any loss, damage, cost or expense suffered as a result of reliance on the information contained in this Report or any actions taken or not taken on the basis of this Report. In particular, results presented in this Report relate exclusively to the samples selected by the Intended Recipient and no responsibility is taken for the representativeness of these samples.

This report shall not be reproduced except in full, without written approval of ASFT.

QD-001R1

Copyright © 2020 ASFT

**THERMAL TESTING OF THE PIVOT STOVES & HEATING ROOM SEAL FLUE KIT  
 TO AS/NZS2918:2018 APPENDIX F**

**Report**

The Pivot Stoves & Heating Room Seal Flue kit was installed in a manner conforming to joint Australian/New Zealand Standard 2918:2018, Appendix F.

The Pivot Stoves & Heating Room Seal Flue kit conforms to the requirements of the joint AS/NZS 2918:2018 Standard, Appendix F.

The Flue system was tested at the following clearances:

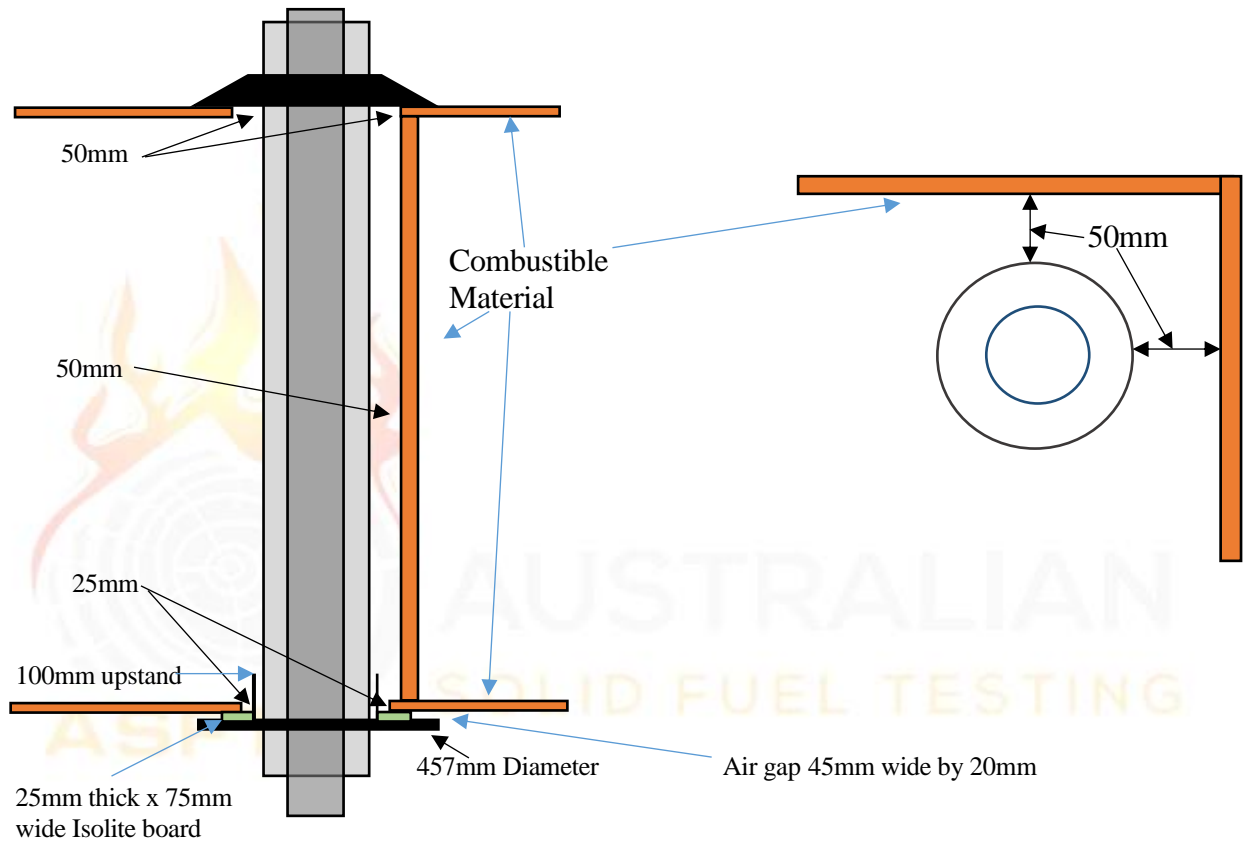

Figure 1 – Clearance Diagram

<b>Signed</b>		<b>Approved</b>	
<b>Name</b>	Garry W. Mooney	<b>Name</b>	Steve Marland
<b>Title</b>	Technical Officer	<b>Title</b>	Managing Director – Australian Solid Fuel Testing
<b>Date</b>	27/05/2020	<b>Date</b>	27/05/2020

## 1. INTRODUCTION

Thermal Clearance testing of the Pivot Stoves & Heating Room Seal Flue kit flue system took place on May 21, 2020 at the Australian Solid Fuel Testing Laboratory located at 3 Garden Street, Morwell, Victoria. The testing was performed by Mr G.W. Mooney and Mr S. Marland.

## 2. PROCEDURE

Testing was conducted as per Appendix F of AS/NZS2918;2018, Hot sites were located with the aid of an infra-red thermometer. Thermocouple tips were stapled onto the test surfaces, with black tape over the first 100 mm to facilitate consistent and accurate recording of temperatures. Thermocouple positions are shown in the table below:

Thermocouple No.	Position	Thermocouple No.	Position
1	Flue gas temperature	17	RHS Wall, 250mm above Ceiling, 200mm from corner
2	Ceiling – Ring Inner Right	18	LHS Wall, 350mm above Ceiling, 200mm from corner
3	Ceiling – 50mm Right	19	RHS Wall, 350mm above Ceiling, 200mm from corner
4	Ceiling – 100mm Right	20	LHS Wall, 450mm above Ceiling, 200mm from corner
5	Ceiling – 150mm Right	21	RHS Wall, 450mm above Ceiling, 200mm from corner
6	Ceiling – 200mm Right	22	LHS Wall, 550mm above Ceiling, 200mm from corner
7	Ceiling – Ring Inner Left	23	RHS Wall, 550mm above Ceiling, 200mm from corner
8	Ceiling – 50mm Left	24	LHS Wall, 1000mm above Ceiling, 200mm from corner
9	Ceiling – 100mm Left	25	RHS Wall, 1000mm above Ceiling, 200mm from corner
10	Ceiling – 150mm Left	26	LHS Wall, 1950mm above Ceiling, 200mm from corner
11	Ceiling – 200mm Left	27	RHS Wall, 1950mm above Ceiling, 200mm from corner
12	LHS Wall, 50mm above Ceiling, 200mm from corner	28	Roof – Ring Inner Front
13	RHS Wall, 50mm above Ceiling, 200mm from corner	29	Roof – Ring Inner Rear
14	LHS Wall, 150mm above Ceiling, 200mm from corner	30	Roof – Ring Inner Left
15	RHS Wall, 150mm above Ceiling, 200mm from corner	31	Roof – Ring Inner Right
16	LHS Wall, 250mm above Ceiling, 200mm from corner	32	Ambient temperature

## 5. RESULTS

### 5.1 Ambient and Test Surface Temperatures

The Table below show the Ambient temperatures during testing of the Flue kit.

Hot Fire	Flue Fire
17.9 – 18.9	17.1 – 19.7

### 5.2 Hot Flue Test

The Flue kit was tested in accordance with Section F8.1 of AS/NZS2918;2018. The Flue gas temperature was maintained between 740°C and 760°C until the maximum temperatures on each surface had been reach.

Below is a table of the maximum temperatures reached above Ambient.

Position	Thermocouple Number	Hot Fire Test (°C)
Ceiling	2	61.5
RHS Wall	28	32.7
LHS Wall	27	41.3
Roof	33	62.2

### 5.3 Flue Fire Test

The Flue kit was tested in accordance with Section F8.2 of AS/NZS2918;2018. The Flue gas temperature was raised from 760 ± 20°C to 1125 ± 20°C within 10minutes, then held at 1125 ± 20°C for a period of 30minutes.

Below is a table of the maximum temperatures reached above Ambient.

Position	Thermocouple Number	Flue Fire Test (°C)
Ceiling	8	83.8
RHS Wall	28	86.2
LHS Wall	27	89.4
Roof	32	99.5

#### **5.4 Structural Integrity Test**

The Pivot Stoves & Heating Room Seal Flue kit was tested in accordance with Section F8.3 of AS/NZS2918;2018. The Flue gas temperature was raised and kept at  $760 \pm 20^{\circ}\text{C}$  then raised to  $1125 \pm 20^{\circ}\text{C}$  within 10minutes, then held at  $1125 \pm 20^{\circ}\text{C}$  for a period of 10minutes. This process was repeated three times.

The Pivot Stoves & Heating Room Seal Flue kit was dismantled the following day and the components inspected for their Structural Integrity.

No Structural Integrity issues were found.

#### **5.4 Uncertainty of Measurement Statement**

5.5.1 The uncertainty of distance measurement for determining clearance distances was not greater than  $\pm 3\text{mm}$ .

5.5.2 The uncertainty of temperature measurement during the entire test period was a maximum of  $\pm 2^{\circ}\text{C}$  at a 95% confidence level.

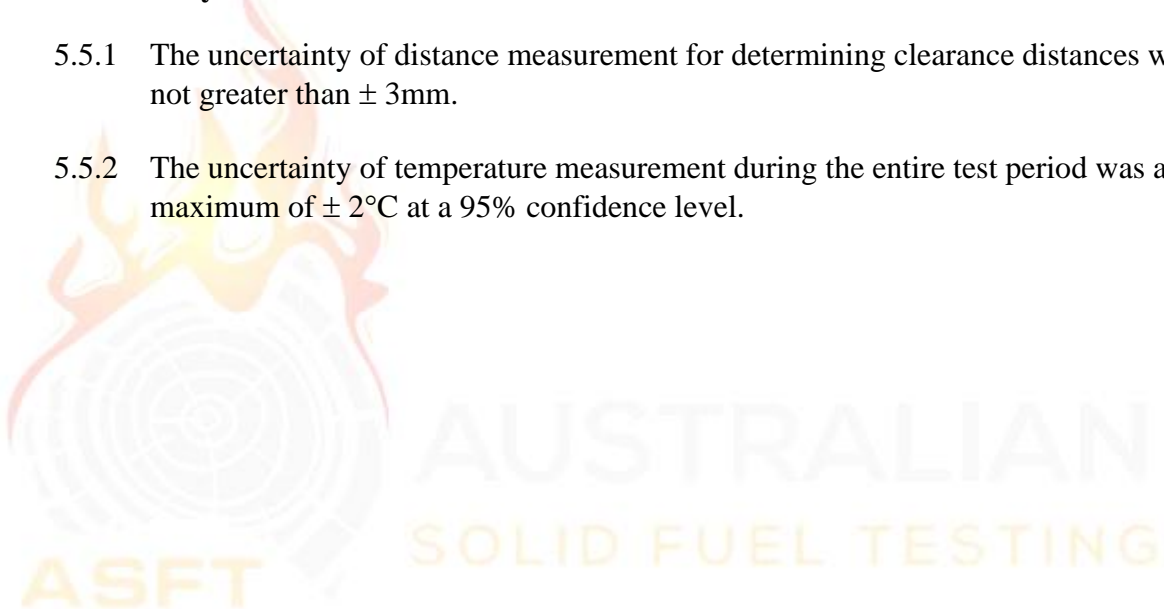

## 6. FLUE KIT CONSTRUCTION DETAILS

The test results reported directly relate to the Flue kit/flue system tested. The details of the Flue kit given in this section include features which may affect safety clearances. Any change in the design/construction of this Flue kit or flue may invalidate this report. Below are the constructions details of the Flue kit:

Flue Model: <b>room seal flue kit</b>	Serial No:
Manufacturer: <b>Pivot Stoves</b>	
Active Flue diameter: 152mm Length: 1000mm Material thickness: 0.5mm 304g No. of Lengths: 2	
Ceiling ring diameter:457mm 100mm upstand with 25mm isolite board on outside of upstand for 75mm (screwed hard to ceiling) then 45mm wide air gap to outside of ring. Made of 1.2mm galvanised steel	
Outer Casing below Ceiling diameter: Outer casing fixed to active and packed with quartz insulation Material Type/Thickness: 0.5mm s/s 316g	Length: 1000mm No. of Lengths:2
1 <sup>st</sup> Outer Casing Above Ceiling diameter: Material Type/Thickness:	Length: No. of Lengths:
2 <sup>nd</sup> Outer Casing Above Ceiling diameter: Material Type/Thickness:	Length: No. of Lengths:
Cowl Height: 260mm Diameter: 300mm	Material Type: s/s
Area of Venting in Cowl: no venting	
<b>NOTE: Accuracy of measurement is <math>\pm 5\%</math> of the measured value</b> <u>Isolite board insulation 25mm</u>	

Below are pictures of the modified ceiling ring that must be installed with the flue kit;



Appendix 1 is thermal images of the flue kit during testing  
 Appendix 2 is the installation manual/Instructions for the flue kit

## 7. CONCLUSION

The Pivot Stoves & Heating Room Seal Flue kit flue kit conforms to the requirements of Australian/New Zealand Standard 2918:2018, when tested in accordance with Appendix F.





### APPENDIX 1: Thermal images of flue during testing

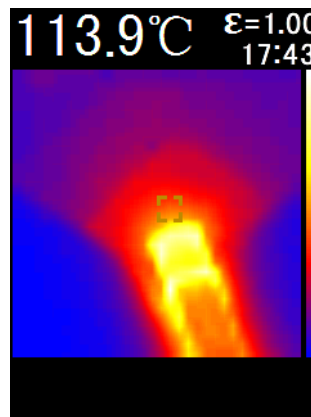

Below the roof

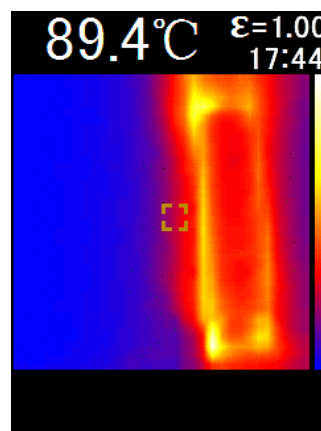

Above the ceiling

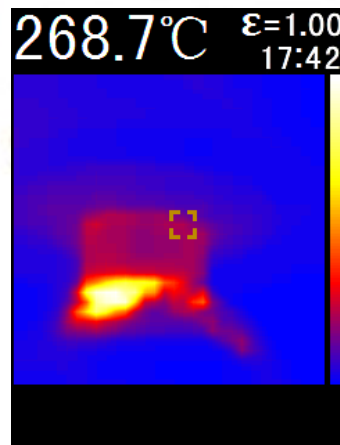

Below ceiling



ALIAN  
EL TESTING

## APPENDIX 2:

# Room Seal Flue Kit

## Installation Manual

The Room Seal Flue Kit is an insulated flue kit that uses ceramic insulation to not only ensure your wood stove/heater's flue is running at the optimum temperature, but also offers a room seal solution for your home

The Room Seal Flue Kit is an air tight solution for **passive homes** – increasing the efficiency of your wood heater by up to **8%**

The ceramic insulation ensures your outer temperature is kept extremely low, allowing you to have timbers as close as 25mm from this flue a the ceiling line, and 50mm from timber at the roof line

### Standard Flue Kit (RSF-6kit)

Item	OTY	Product Code
A 1000mm 6" Single skin flue Painted black Diameter: 150mm	2	RFS-6PAINT
B 1000mm starter length, end painted for drop box Inside diameter: 150mm Outside diameter: 200mm	1	RSF-1000 Starter
C 1000mm Room Sealed Flue (with Locking Band) Inside diameter: 150mm Outside diameter: 200mm	1	RSF-1000
D 1000mm Heat Shield Black	1	RFS-SHIELD
E Ceiling Ring	1	Choose correct ceiling ring pitch, see extra parts for options
F 8" Wind Cowl Stainless Steel Inside diameter: 150mm Outside diameter: 200mm	1	RFS-COWL
G Room Sealed Flue Adapter Single to twin 150mm - 200mm	1	RSF-STARTER

### Extra Parts

Item	Product Code
H 500mm Room Sealed Flue (with Locking Band) Inside diameter: 150mm Outside diameter: 200mm	RSF-500
I 340-500mm Adjustable Room Sealed Flue (with Locking Band) Inside diameter: 150mm Outside diameter: 200mm	RSF-ADJUST
J 90 Degree Tee with Cap and Locking Band Inside diameter: 150mm Outside diameter: 200mm	RSF-Tee
K End Cap Inside diameter: 150mm Outside diameter: 200mm	RFS-Cap
L 45 Degree Bend with Locking Band Inside diameter: 150mm Outside diameter: 200mm	RSF-45oBEND
M Locking Band Diameter: 200mm	RSF-Lockband
N Roof Support Brace (optional) Inside diameter: 150mm Outside diameter: 200mm	RFS-BRACE
E Ceiling Ring Options	0°: RFS-CEILINGRING 5°: RFS-5CEILINGRING 15°: RFS-15CEILINGRING 30°: RFS-30CEILINGRING 45°: RFS-45CEILINGRING

**PIVOT**  
stove & heating

Address: 120 Victoria street, Nth Geelong  
Phone: 1300 4 PIVOT / 1300 474 868  
Website: Pivotstove.com.au

The flue is tested to XXXXXX | Approval number XXXXX

1

## Room Seal Flue Kit

### Installation Manual

Standard Ceiling  
 4m Flue Kit

#### Flue Assembly

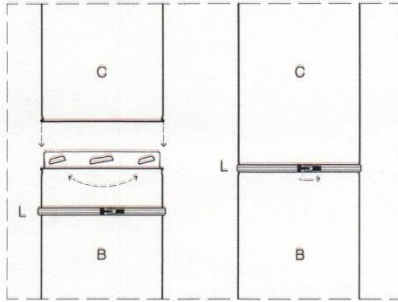

NOTE:  
 To assemble flue, first lock into place, second secure locking band around joint

#### Optional Support Brace

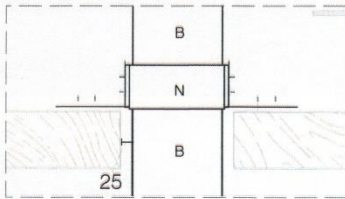

NOTE:  
 The optional support brace (N) has the ability to adjust to any angle of adjacent roof beams  
 \*There is a 25mm clearance between the flue and any timber at all times\*

#### Starter Length

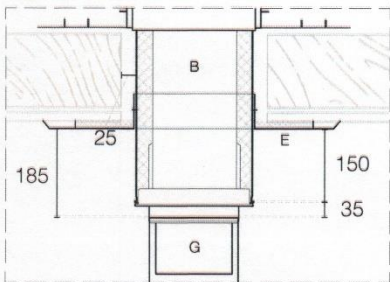

NOTE:  
 150mm single skin flue (A) must terminate 185mm from the ceiling. The 200mm starter length (B) dropping 150mm into the room, with the tail dropping into the A flue  
 \*There is a 25mm clearance between the flue and any timber at all times\*

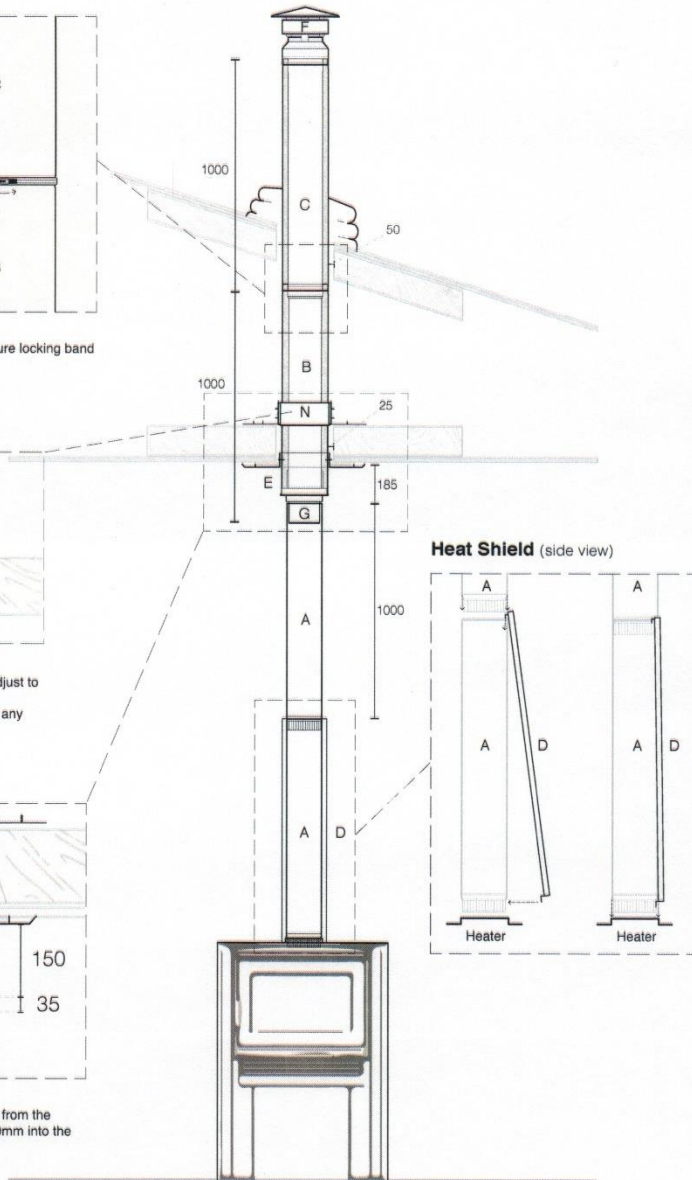

#### Heat Shield (side view)

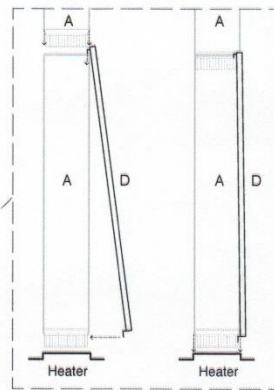

**PIVOT**  
 stove & heating

Address: 120 Victoria street, Nth Geelong  
 Phone: 1300 4 PIVOT / 1300 474 868  
 Website: Pivotstove.com.au

The flue is tested to XXXXXX | Approval number XXXXX

2

## Room Seal Flue Kit

### Installation Manual

### Reduced Clearance 4m Flue Kit

#### Ceiling Ring

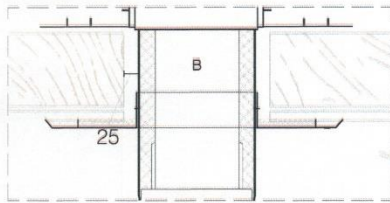

NOTE:  
 \*There is a 25mm clearance between the flue and any timber at all times\*

#### Flue Assembly

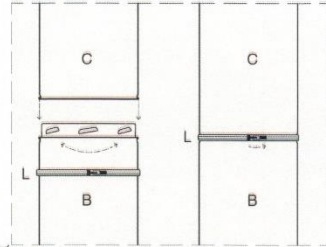

NOTE:  
 To assemble flue, first lock into place, second secure locking band around joint

#### Reduced Clearance Flue Kit

Item	QTY	Product Code
O 1000mm RSF, painted black (with Locking Band) Inside diameter: 150mm Outside diameter: 200mm	2	RFS-1000-black
B 1000mm starter length, end painted for drop box Inside diameter: 150mm Outside diameter: 200mm	1	RSF-1000 Starter
C 1000mm Room Sealed Flue (with Locking Band) Inside diameter: 150mm Outside diameter: 200mm	1	RSF-1000
E Ceiling Ring	1	Choose correct ceiling ring pitch, see extra parts for options
F 8" Wind Cowl Stainless Steel Inside diameter: 150mm Outside diameter: 200mm	1	RFS-COWL
G Room Sealed Flue Adapter Single to twin 150mm - 200mm	1	RSF-STARTER

#### Optional Support Brace

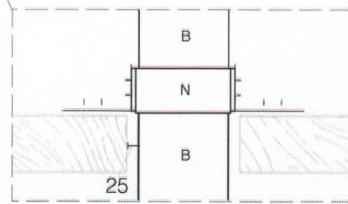

NOTE:  
 The optional support brace (N) has the ability to adjust to any angle of adjacent roof beams  
 \*There is a 25mm clearance between the flue and any timber at all times\*

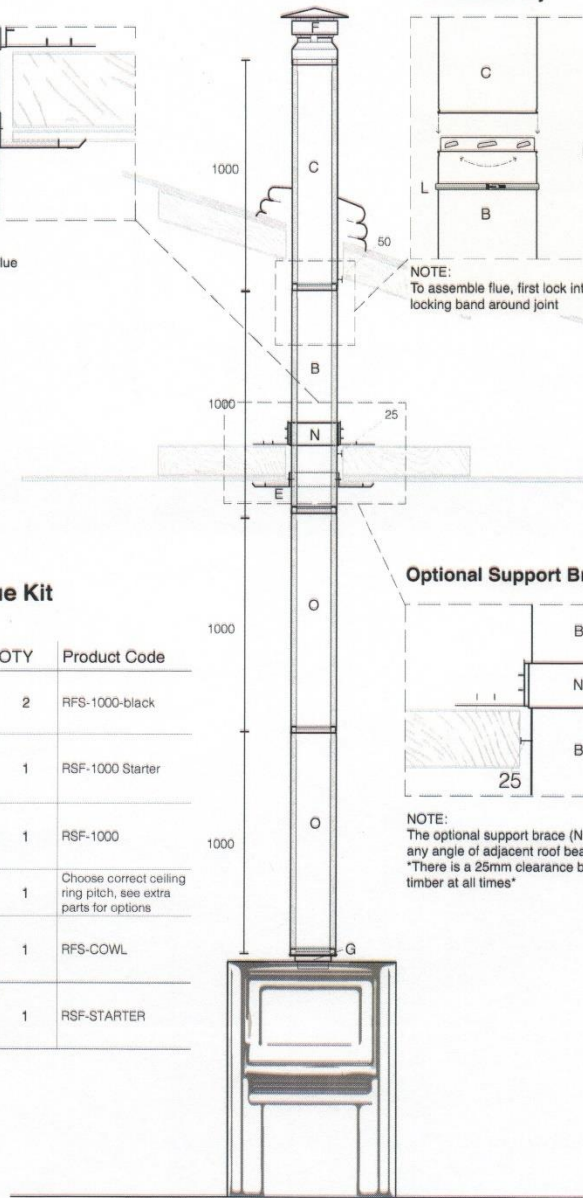

## Room Seal Flue Kit

### Installation Manual

### Cathedral Ceiling 4m Flue Kit

#### Flue Assembly

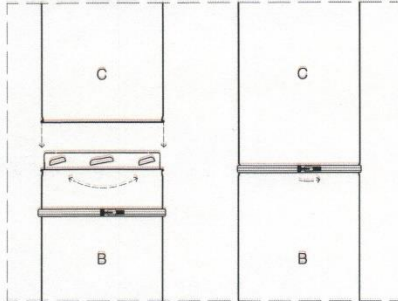

NOTE:  
 To assemble flue, first lock into place, second secure locking band around joint

#### Optional Support Brace

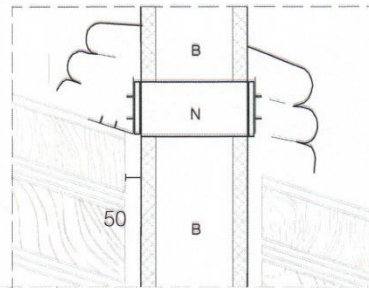

NOTE:  
 The optional support brace (N) has the ability to adjust to any angle of adjacent roof beams  
 \*There is a 25mm clearance between the flue and any timber at all times\*

#### Heat Shield (side view)

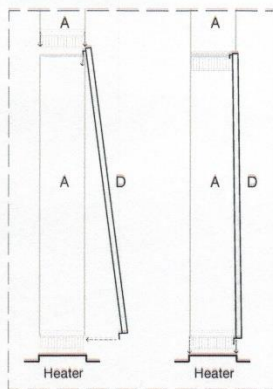

NOTE:  
 The heat shield should be positioned on the side of the flue that faces the nearest wall for additional protection

#### Starter Length

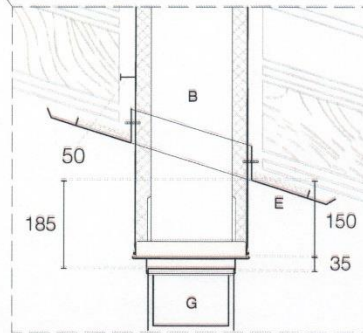

NOTE:  
 150mm single skin flue (A) must terminate 185mm from the ceiling (lowest point the flue passes through). The 200mm starter length (B) dropping 150mm into the room, with the tail dropping into the A flue  
 \*There is a 25mm clearance between the flue and any timber at all times\*

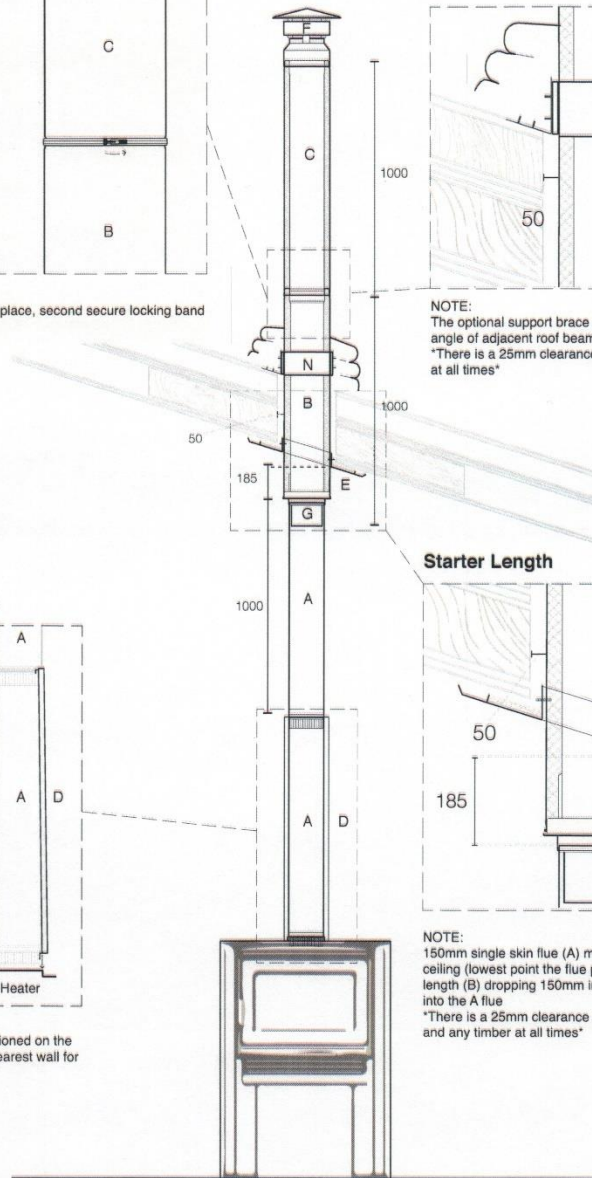

# Room Seal Flue Kit

## Installation Manual

### Terminating Clearance

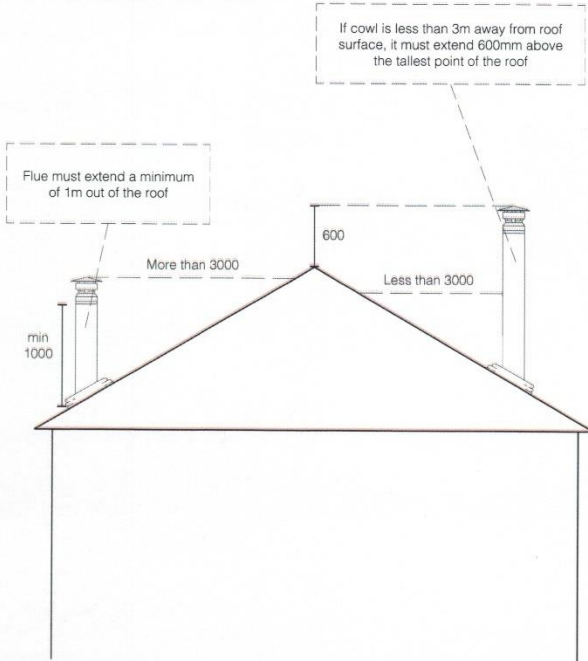

### Ceiling Bends

If there are any obstructions in the roof cavity above the wood heater location, the flue may need to include a bend.

NOTE: flue bend must not exceed beyond 900mm horizontally from the starting flue location.

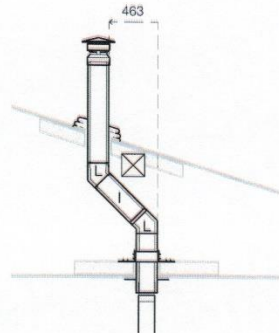
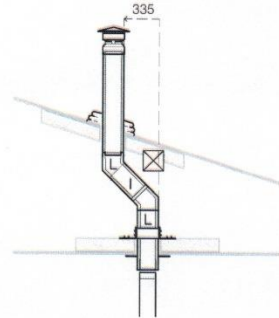
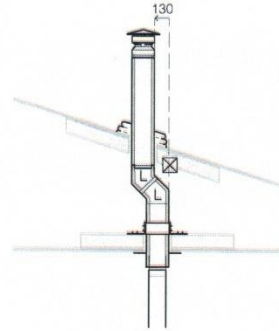

**PIVOT**  
stove & heating

Address: 120 Victoria street, Nth Geelong  
Phone: 1300 4 PIVOT / 1300 474 868  
Website: Pivotstove.com.au

The flue is tested to XXXXXX | Approval number XXXXX