

ITEM NO.	PART NUMBER	DESCRIPTION	QTY.
1	500-IH-001	500 IRONHEART OVEN ASSEMBLY	1
2	900-004A	BOILER	1
3	990-009	VERMICULITE REAR BRICK	2
4	500-IH-226	500 IRONHEART R/H & L/H REAR SIDE BRICK	2
5	500-IH-227	500 IRONHEART R/H & L/H FRONT SIDE BRICK	4
6	990-004	FIRE BOX TOP BACK BRICK	1
7	500-IH-235	FIRE BOX TOP FRONT BRICK	1
8	990-009B	VERMICULITE BASE BRICK	1
9	990-009C	VERMICULITE FRONT BRICK	1

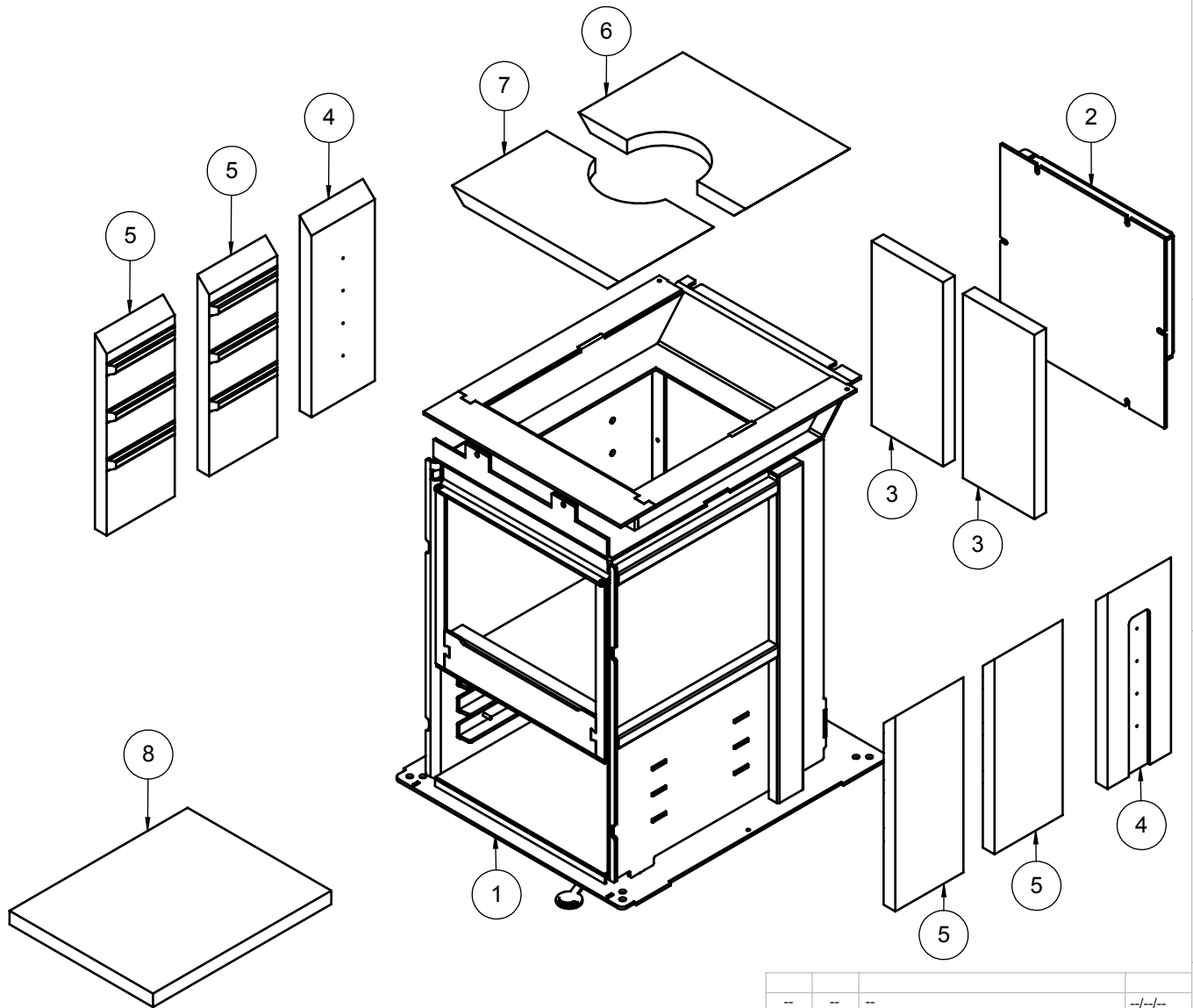

Drawn By: M ALEXANDER Date: 05/09/2017

CHK'D

APP'VD

UNLESS OTHERWISE SPECIFIED:
DIMENSIONS ARE IN MILLIMETERS
TOLERANCES: ±0.5mm
LINEAR:
ANGULAR:

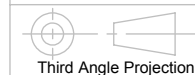

DO NOT SCALE DRAWING

Material:

Finish:

DEBUR AND REMOVE SHARP EDGES

REV	BY	DESCRIPTION	DATE

Esse Engineering
Ouzledale Foundry
Long Ing Lane
Barnoldswick
Lancashire
BB18 6BN
Tel: 01282 813235
Web: www.esse.com

TITLE:
500 IRONHEART FIREBOX ASSEMBLY

DWG. NO. **500-IH-002** Revision

SHEET 1 OF 1 SCALE: 1:10 **A4**